

# Blue Diamond™ Wrought Nut Eye Bolts

Stock No.	Thread Dia.	I.D. Eye A	Thread Length B	Shank Length C	Overall Length D	Approx. Wt. Per 100 Pcs.
21368	<b>6-32</b>	1/4	15/16	1	1 1/2	1.0
21370	<b>8-32</b>	1/4	1	1 1/16	1 5/8	1.2
21371	<b>8-32</b>	3/8	1	1 1/16	1 3/4	1.4
21380	<b>10-24</b>	5/16	1 1/8	1 1/4	1 15/16	1.6
21381	<b>10-24</b>	3/8	7/8	1	1 11/16	1.5
21382	<b>10-24</b>	3/8	1	2	2 11/16	2.0
21383	<b>10-24</b>	3/8	1 1/2	3	3 11/16	2.5
21384	<b>10-32</b>	11/32	9/32	3/16	1 1/16	1.0
21390	<b>12-24</b>	3/8	1 3/8	1 7/16	2 3/16	2.5
21400	<b>1/4-20</b>	9/16	7/8	1	2	3.6
21410	<b>1/4-20</b>	9/16	1 3/8	1 1/2	2 1/2	4.0
21420	<b>1/4-20</b>	3/8	1 1/2	1 13/16	2 5/8	4.0
21430	<b>1/4-20</b>	9/16	1 1/2	2	3	4.6
21440	<b>1/4-20</b>	9/16	1 1/2	2 1/2	3 1/2	5.2
21450	<b>1/4-20</b>	9/16	1 1/2	3	4	5.4
21451	<b>1/4-20</b>	9/16	1 1/2	3 1/2	4 1/2	6.3
21460	<b>1/4-20</b>	9/16	1 1/2	4	5	6.6
21470	<b>1/4-20</b>	9/16	1 1/2	5	6	7.0
21500	<b>5/16-18</b>	1/2	2	2 3/16	3 1/4	7.8
21510	<b>5/16-18</b>	3/4	1 7/8	1 15/16	3 1/4	8.2
21520	<b>5/16-18</b>	3/4	2	2 5/8	4	9.9
21530	<b>5/16-18</b>	3/4	2 1/2	3 3/8	5	11.6
21540	<b>5/16-18</b>	3/4	2 1/2	4 5/8	6	13.4
21600	<b>3/8-16</b>	5/8	2 3/8	2 1/2	3 7/8	13.2
21610	<b>3/8-16</b>	1	2 1/8	2 1/4	4	15.7
21620	<b>3/8-16</b>	1	2 1/2	3 1/4	5	16.8
21630	<b>3/8-16</b>	1	2 1/2	4 1/4	6	20.6
21640	<b>3/8-16</b>	1	2 1/2	6 1/4	8	25.3
21650	<b>3/8-16</b>	1	2 1/2	7 3/8	9 1/2	29.2
21660	<b>3/8-16</b>	1	2 1/2	9 7/8	11 1/2	37.0
21670	<b>3/8-16</b>	1	2 1/2	11 7/8	13 1/2	41.0
21700	<b>7/16-14</b>	1	2 1/2	4	6	27.2
21710	<b>7/16-14</b>	1	2 1/2	6	8	35.3
21720***	<b>7/16-14</b>	1	2 1/2	8	10	41.8
21730***	<b>7/16-14</b>	1	2 1/2	10	12	48.5
21740	<b>1/2-13</b>	1	2 3/4	3	5	34.0
21750	<b>1/2-13</b>	1	3	4	6	37.3
21760	<b>1/2-13</b>	1	3	5	7	42.3
21770	<b>1/2-13</b>	1	3	6	8	46.2
21780	<b>1/2-13</b>	1	3	8	10	54.3
21790	<b>1/2-13</b>	1	3	10	12	63.5
21800	<b>5/8-11</b>	1 1/4	3	3 1/2	6	62.5
21810***	<b>5/8-11</b>	1 1/4	3	5 1/2	8	74.6
21820	<b>5/8-11</b>	1 1/4	3	7 1/2	10	90.5
21830***	<b>5/8-11</b>	1 1/4	3	9 1/2	12	103.5

\*\*\*These products will be discontinued when stock is depleted.

Stock No.	Thread Dia. A	Overall Length B	Shank Length C	Thread Length D	I.D. Eye E	Wt. Per 100 Pcs.
SS21400	<b>1/4-20</b>	2	1	7/8	9/16	3.6
SS21420	<b>1/4-20</b>	2 5/8	1 13/16	1 1/2	3/8	4.0
SS21440	<b>1/4-20</b>	3 1/2	2 1/2	1 1/2	9/16	5.2
SS21450	<b>1/4-20</b>	4	3	1 1/2	9/16	5.4
SS21500	<b>5/16-18</b>	3 1/4	2 3/16	2	1/2	7.8
SS21520	<b>5/16-18</b>	4	2 5/8	2	3/4	9.9
SS21601	<b>3/8-16</b>	3	1 3/4	1	1	13.0
SS21610	<b>3/8-16</b>	4	2 1/4	2 1/8	1	15.7
SS21630	<b>3/8-16</b>	6	4 1/4	2 1/2	1	20.6
SS21640***	<b>3/8-16</b>	8	6 1/4	2 1/2	1	25.3

Furnished with stainless steel hex nuts (unassembled).

Available bulk only.

All stainless electropolished.

\*\*\*These products will be discontinued when stock is depleted.

## Bent Eyes

- 1010 Carbon Steel
- Zinc Plated

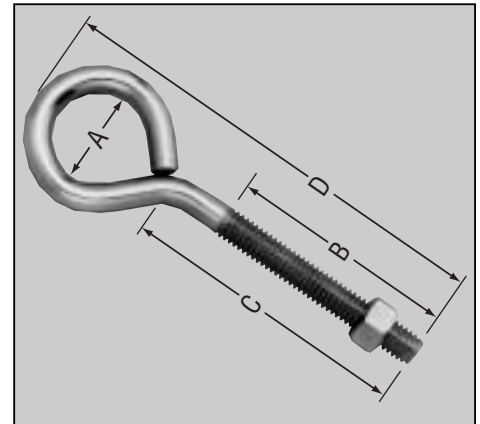

**NOT RECOMMENDED FOR LIFTING**

- Furnished with hex nuts (unassembled)
- All sizes manufactured with rolled threads

## Stainless Steel Wrought Eye Bolts

- 304 Stainless Steel

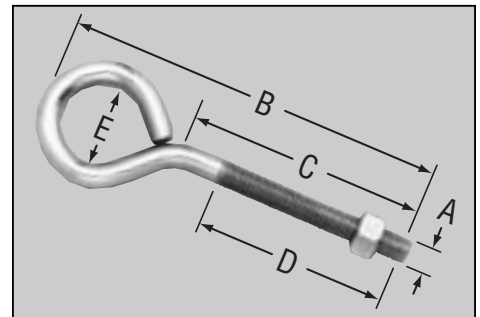

**NOT RECOMMENDED FOR LIFTING**

To Place an Order or for More Information Please Call  
**1-800-338-2658** or visit our website at [www.ewdaniel.com](http://www.ewdaniel.com)

# Blue Diamond™ Wrought Nut Eye Bolts

## Bent Eyes Welded Closed

- 1010 Carbon Steel
- Zinc Plated

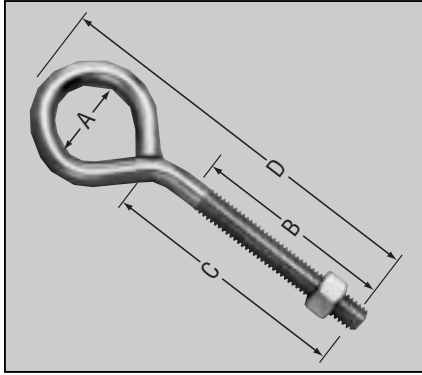

**NOT RECOMMENDED  
FOR LIFTING**

- Furnished with hex nuts (unassembled)
- All sizes manufactured with rolled threads

Stock No.	Thread Dia.	I.D. Eye A	Thread Length B	Shank Length C	Overall Length D	Approx. Wt. Per 100 Pcs.
24500	1/4-20	9/16	7/8	1	2	3.6
24510	1/4-20	9/16	1 1/8	1 1/2	2 1/2	4.0
24530	1/4-20	9/16	1 1/2	2	3	4.6
24540	1/4-20	9/16	1 1/2	3	4	5.4
24550	1/4-20	9/16	1 1/2	4	5	6.6
24560	1/4-20	9/16	1 1/2	5	6	7.0
24630	5/16-18	3/4	1 7/8	1 15/16	3 1/4	8.2
24640	5/16-18	3/4	2	2 5/8	4	9.9
24650	5/16-18	3/4	2 1/2	3 5/8	5	11.6
24660	5/16-18	3/4	2 1/2	4 5/8	6	13.4
24740	3/8-16	1	2 1/8	2 1/4	4	15.7
24750	3/8-16	1	2 1/2	3 3/4	5	16.8
24760	3/8-16	1	2 1/2	4 1/4	6	20.6
24780***	3/8-16	1	2 1/2	6 1/4	8	25.3

\*\*\*These products will be discontinued when stock is depleted.

# Blue Diamond™ U-Bolts

## U-Bolts Unassembled with Nuts

- 1010 Carbon Steel
- Zinc Plated

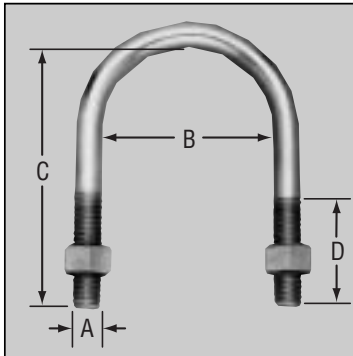

- All sizes manufactured with rolled threads.

Stock No.	Thread Dia. Inches A	Width Bet. Legs Inches B	Inside Length Inches C	Thread Length Inches D	Pipe Size Inches	Wt. Per 100 Pcs.
34010	1/4-20	3/4	1 1/4	3/4	3/8	4.8
34020	1/4-20	3/4	1 3/4	3/4	3/8	5.8
34030	1/4-20	3/4	2 1/4	1 1/2	3/8	6.8
34070	1/4-20	1	1 3/4	3/4	1/2	6.0
34080	1/4-20	1 1/8	2	3/4	3/4	6.5
34090	1/4-20	1 3/8	2 1/4	3/4	1	7.4
34100	1/4-20	1 3/4	2 3/4	1	1 1/4	8.5
34110	1/4-20	2	3 1/4	1 1/4	1 1/2	9.5
34120	1/4-20	1 1/2	3 1/2	2	1	9.8
34200	5/16-18	1 3/8	2 3/16	1	1	11.6
34210	5/16-18	1 3/8	3 1/16	1 1/2	1	16.5
34220	5/16-18	1 3/4	2 1/16	1	1 1/4	13.6
34240	5/16-18	2	2 1/16	1	1 1/2	13.6
34250	5/16-18	2	3 1/16	1 1/2	1 1/2	17.2
34270	5/16-18	2 1/2	3 3/16	1 1/2	2	16.0
34292	3/8-16	1	2 1/4	1 1/4	1/2	17.7
34301	3/8-16	1 3/8	3 1/8	1 1/2	1	21.5
34303	3/8-16	1 1/2	2 1/2	1 1/4	1	19.2
34304	3/8-16	2	3 1/8	1 1/4	1 1/2	23.0
34310	3/8-16	2 1/2	3 5/8	1 1/2	2	24.9
34320	3/8-16	3	4 1/8	1 1/2	2 1/2	28.0
34330	3/8-16	3 5/8	4 5/8	1 1/2	3	32.3
34400	1/2-13	3	4 1/2	1 1/2	2 1/2	58.0
34410	1/2-13	3 1/2	5	1 1/2	3	66.5
34420	1/2-13	4	5 1/2	1 1/2	3 1/2	68.0
34430	1/2-13	4 5/8	6	1 1/2	4	74.0
34440***	1/2-13	5 5/8	7	2	5	86.5
34450	1/2-13	6 3/4	8	2	6	101.5
34455	1/2-13	8 3/4	10 3/8	2	8	125.0
34474***	5/8-11	8 3/4	11 1/2	4	8	253.0

\*\*\*These products will be discontinued when stock is depleted.